

# Mount-n-Lock® ShakeStopper® Assembly Pictorial

For H4HZ, H5HZ, H6HZ, H4HZD, H5HZD, and H6HZD Models

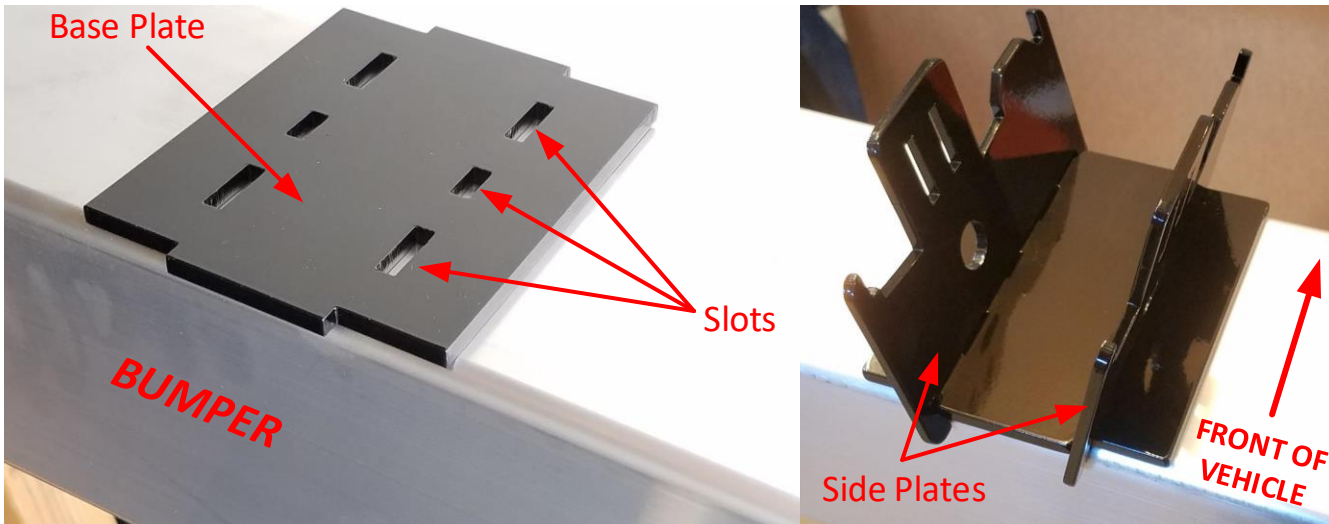

1. Set Base Plate on top of Bumper as shown. 2. Properly orient Side Plates in relationship to front of vehicle as shown and insert into Slots of Base Plate. Note: H4HZ(D) Side Plates are reversible.

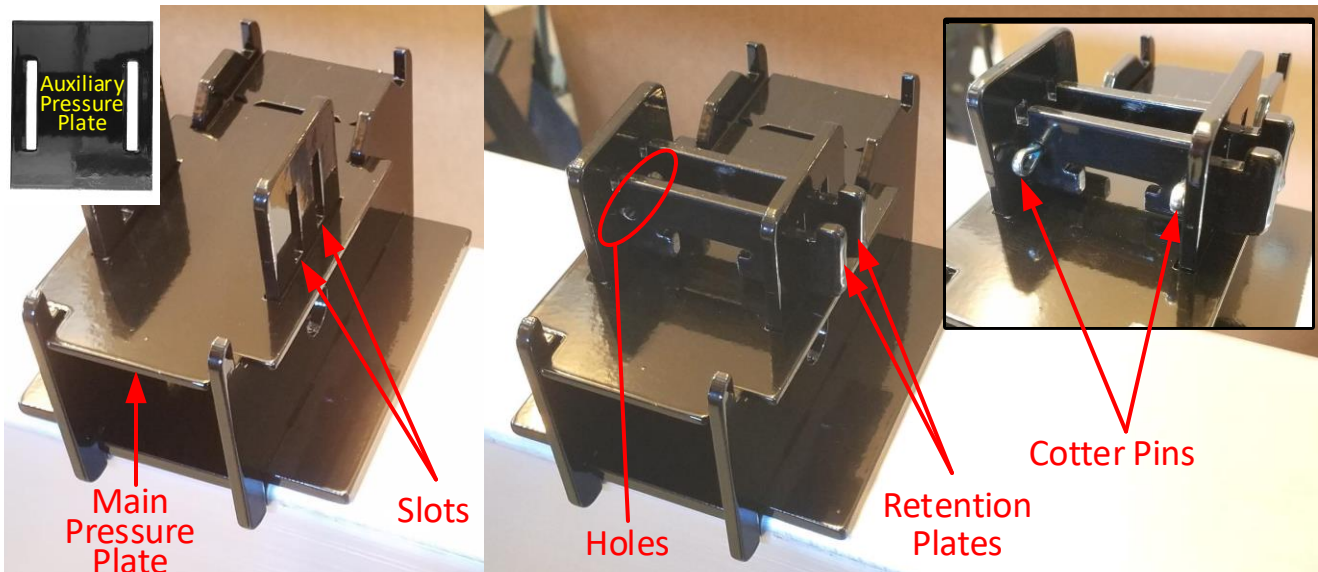

3. Set Main Pressure Plate atop Side Plates as shown. **HxHZD Models Only:** Set Auxiliary Pressure Plate atop Main Pressure Plate.

4. Slide 2 Retention Plates through slots in Side Plates with large center notch toward Pressure Plate. Insert the 2 Cotter Pins into holes in plates; bend pin legs to hold in place.

# ShakeStopper® CLAMPING HITCH

## ASSEMBLY GUIDE

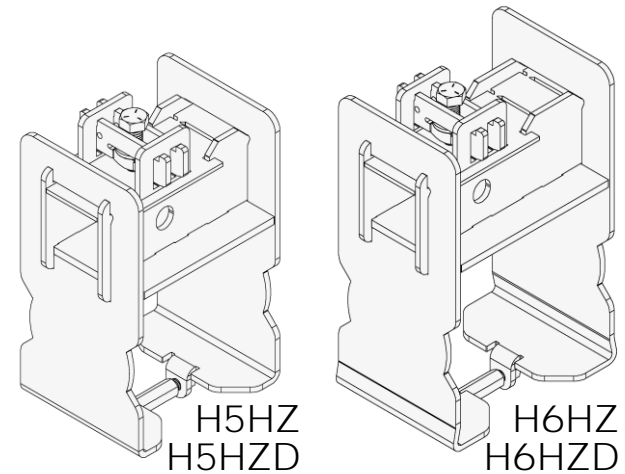
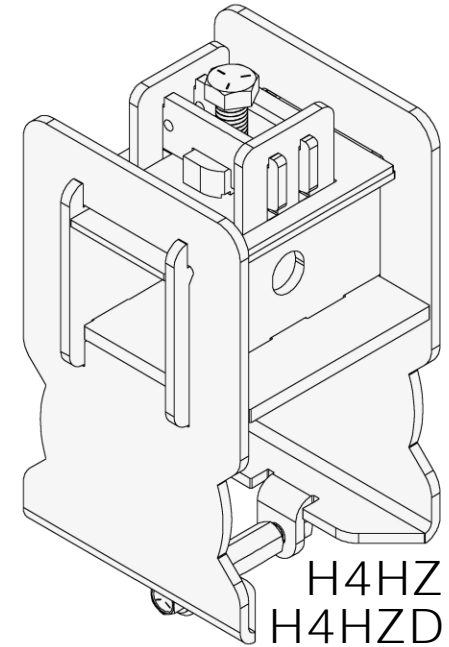

Visit [www.mount-n-lock.com/installs](http://www.mount-n-lock.com/installs) for full-size instructions.

© Copyright 2022 BetterBilt Solutions LLC. All Rights Reserved.

1



Proudly Made in the USA

**Haul It All!**

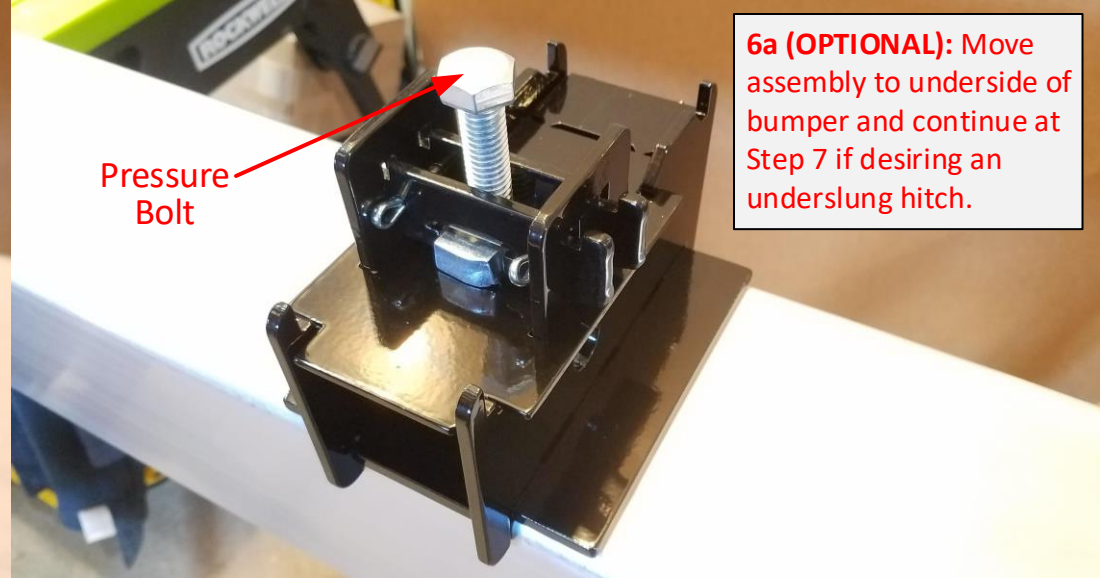
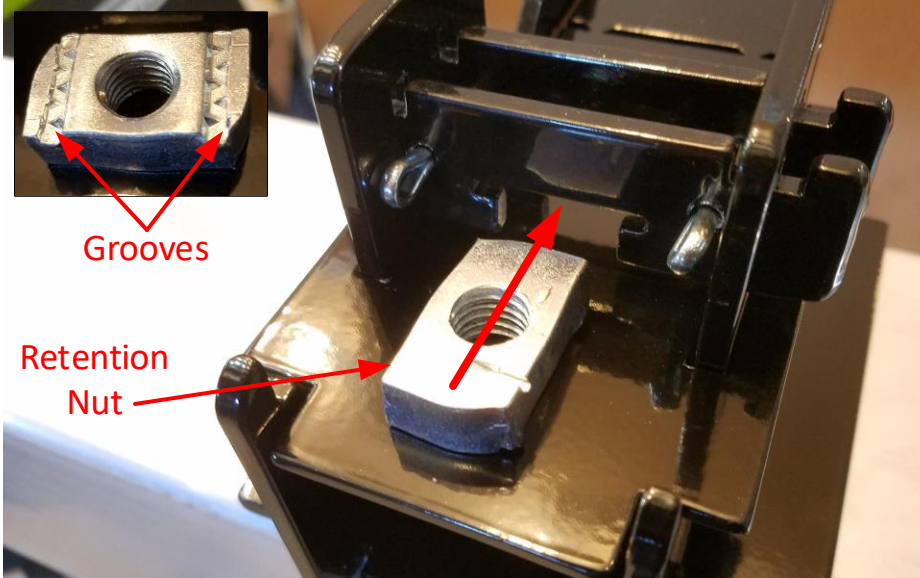

**6a (OPTIONAL):** Move assembly to underside of bumper and continue at Step 7 if desiring an underslung hitch.

5. Slide Retention Nut through openings in Retention Plates. Center nut between plates (Note: Grooves in nut go against Pressure Plate).

6. Thread Pressure Bolt into Retention Nut until nut lifts Retention Plates and tip of bolt rests lightly against Pressure Plate. **DO NOT DEFORM PRESSURE PLATE!**

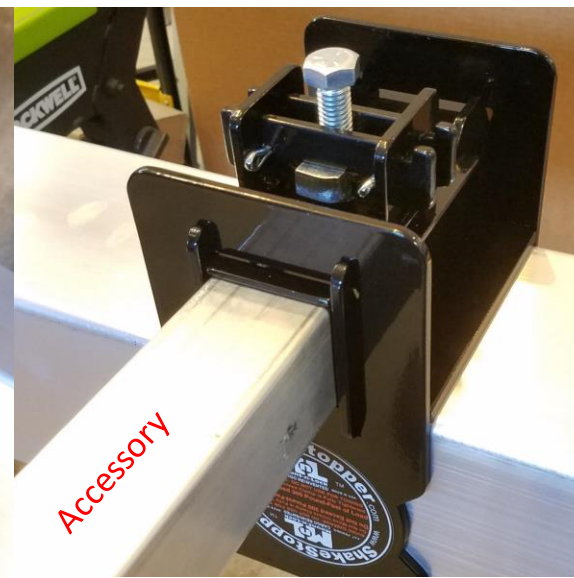
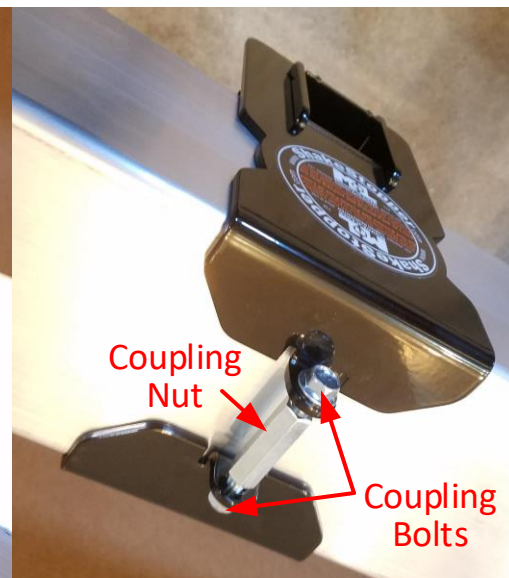
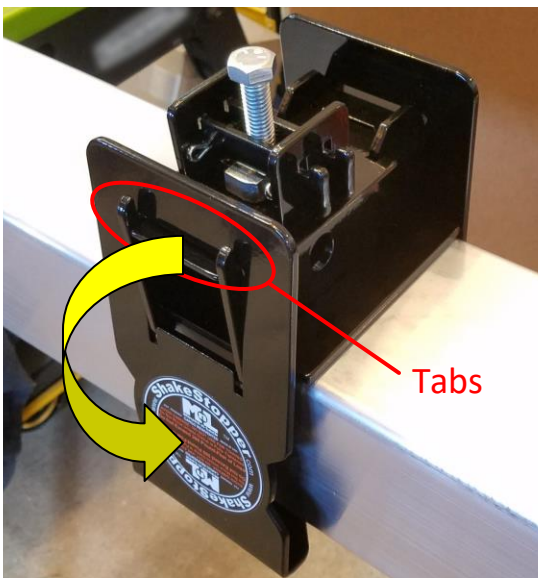

**! PROPER USE**

1. Hitch Pin Required.
2. Do Not Tighten Threaded Hitch Pins or Any Other Anti-Rattle Devices.
3. Pressure Bolt Torque: 20 lb-ft/*Pressure Plate*.
4. Do Not Overload. Visit [mount-n-lock.com/pound-feet](http://mount-n-lock.com/pound-feet) for Maximum Rated Capacity.



7. Add front and rear Face Plates. Hook Face Plates over Tabs on Side Plates and swing into place.

8. Connect Face Plates using Coupling Nut and Bolts. Finger tighten only. *Seeing exposed bolt threads is okay.*

9. Insert Accessory into Hitch, tighten Pressure Bolt until no movement, then wrench-tighten Coupling Bolts to clamp Hitch to Bumper. Loosen Pressure Bolt to remove accessory. **Hitch is now ready to use!**

Visit [www.mount-n-lock.com/installs](http://www.mount-n-lock.com/installs) for full-size instructions.