

# Mount-n-Lock® ShakeStopper® Assembly Pictorial For HC53HZ and HC53HZD Models

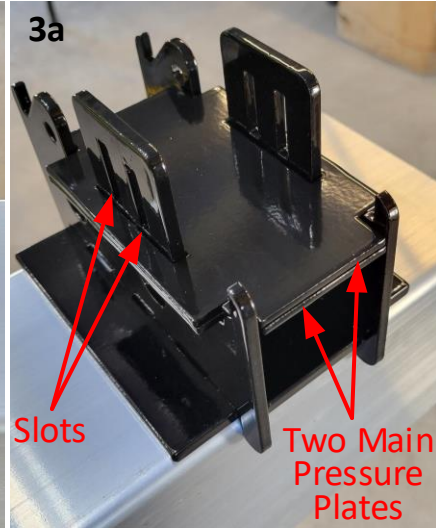

1. Set Base Plate on top of Bumper. 2. Insert Side Plates into Slots of Base Plate; Note orientation to front of vehicle. 3a. Set two Main Pressure Plates atop Side Plates as shown (Plates are reversible).

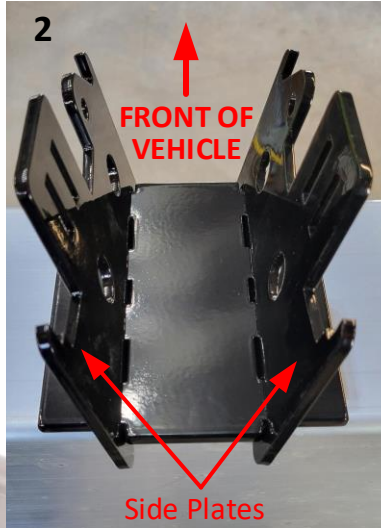
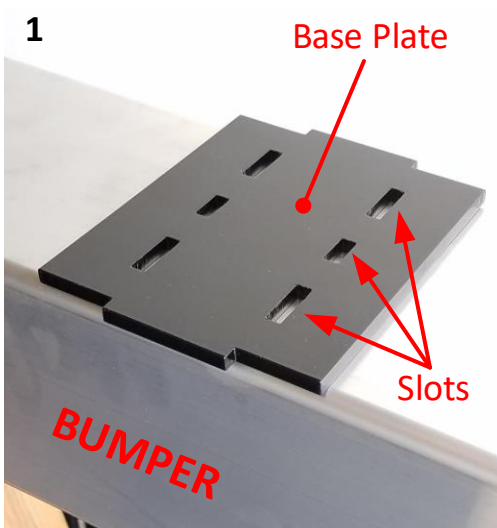
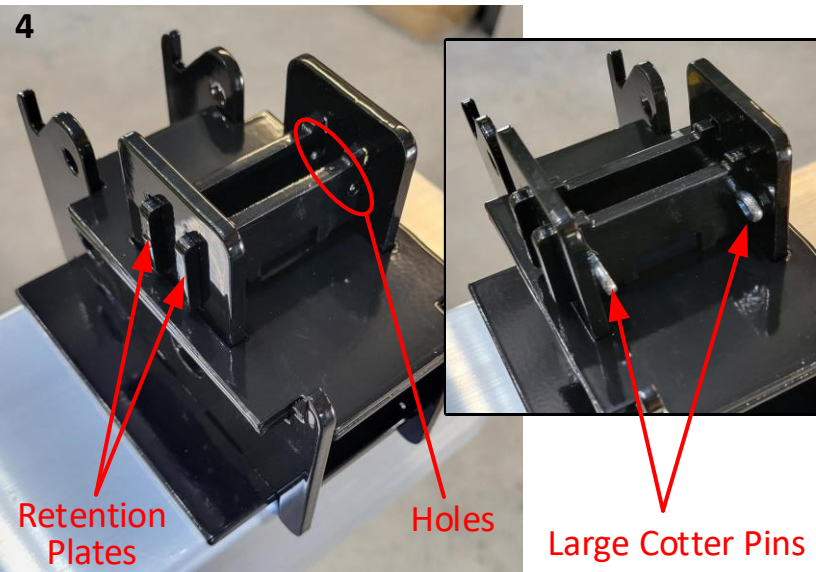
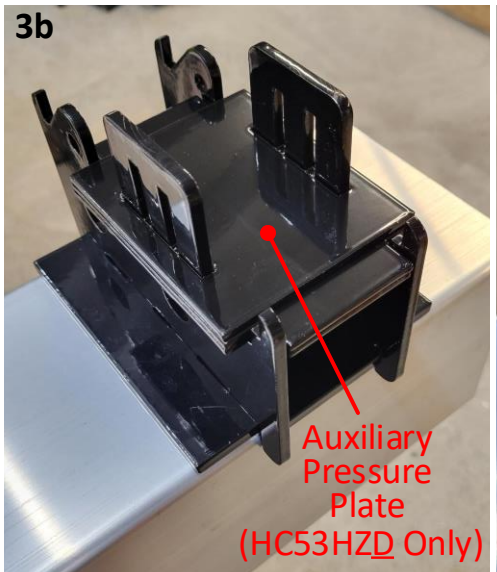

3b. (HC53HZD Only) Set Auxiliary Pressure Plate atop Main Pressure Plates as shown.  
4. Slide two Retention Plates through slots in Side Plates with large center notch toward Pressure Plate. Insert the two Large Cotter Pins into holes in Retention Plates; expand cotter pin legs.

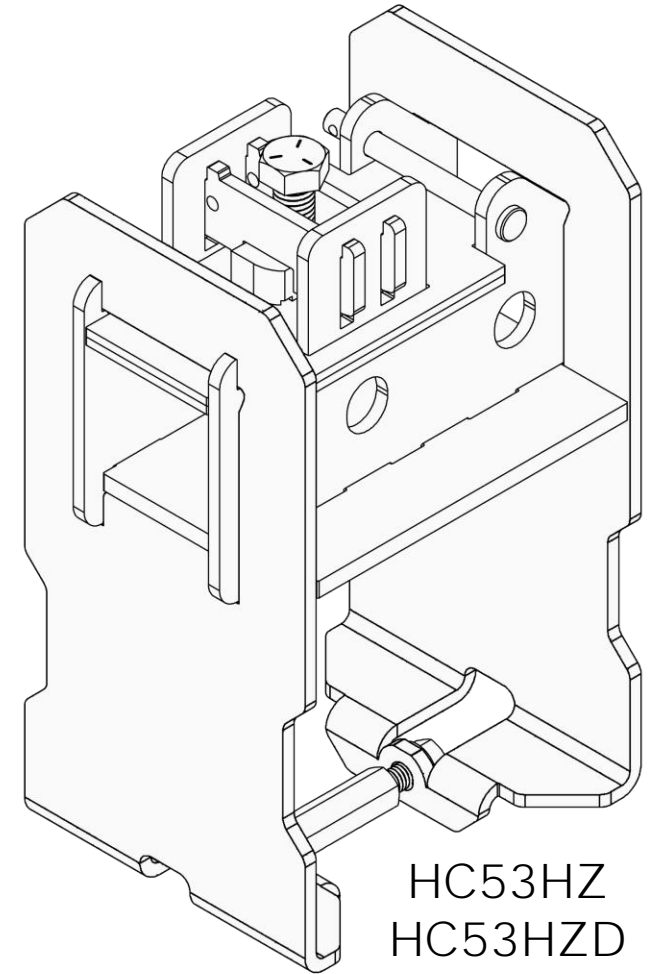

Visit [www.mount-n-lock.com/installs](http://www.mount-n-lock.com/installs) for full-size instructions.

© Copyright 2024 BetterBilt Solutions LLC. All Rights Reserved.

# Mount-n-Lock® ShakeStopper® Assembly Pictorial For HC53HZ and HC53HZD Models

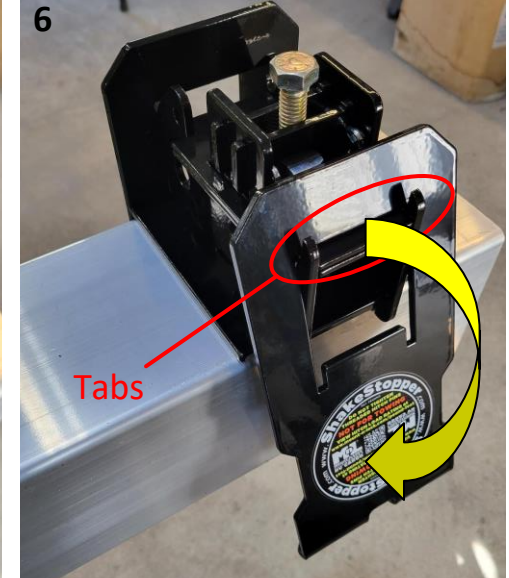
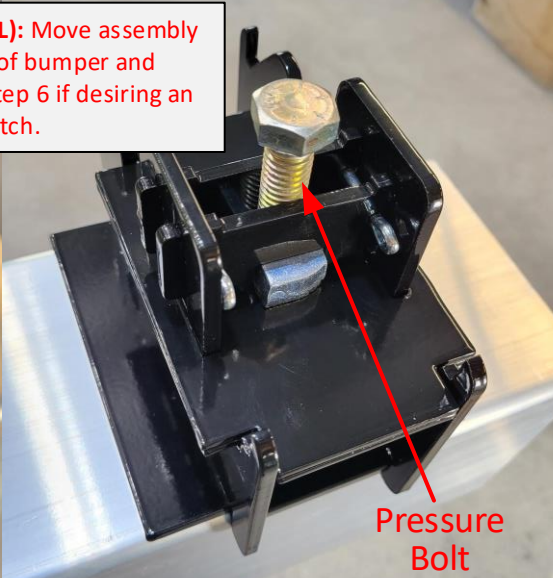
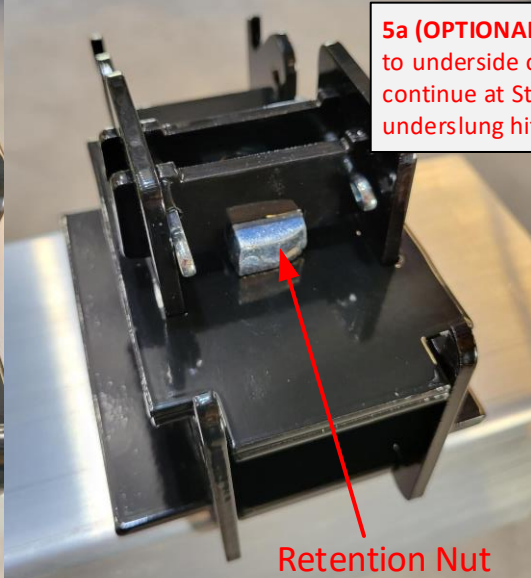
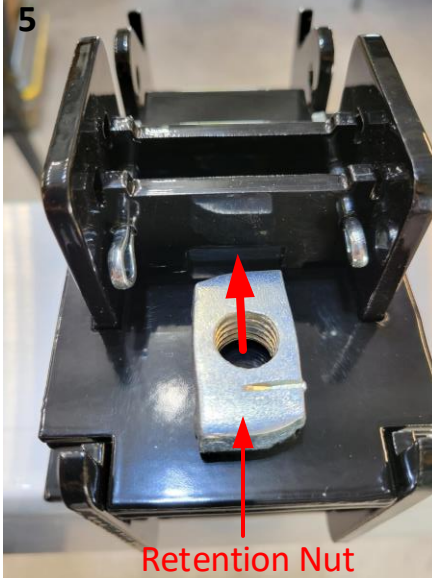

5. Slide Retention Nut through openings in Retention Plates. Center nut between plates. Thread Pressure Bolt into Retention Nut until assembly is snug. **DO NOT TIGHTEN ANY FURTHER (FOR NOW)!**

6. Hook Face Plates over Tabs on Side Plates and swing into place.

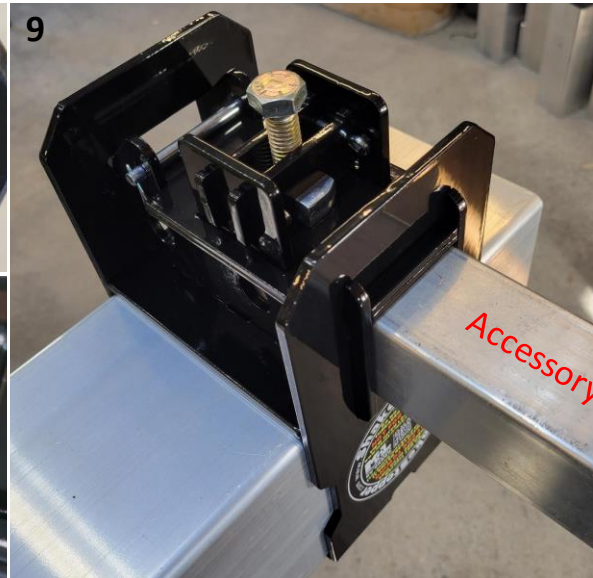
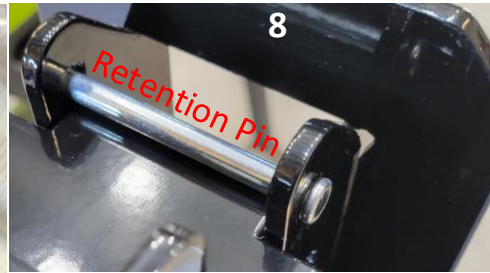

**! PROPER USE**

1. Use of Hitch Pin Required.
2. Do Not Tighten Threaded Hitch Pins or Use Any Other Anti-Rattle Devices.
3. Pressure Bolt Torque Recommendation (lb-ft): **HC53HZ: 40 / HC53HZD: 60**
4. Do Not Ever Overload. Visit Us for Maximum Rated Capacity.

[mount-n-lock.com/pound-feet](http://mount-n-lock.com/pound-feet)

7. Connect Face Plates using Coupling Nut and Bolts. Finger tighten only. *Seeing exposed bolt threads is okay.*

8. Insert Retention Pin through Side Plates, then insert/expand small Cotter Pin.

9. Insert Accessory into Hitch, tighten Pressure Bolt until no movement, then wrench-tighten Coupling Bolts to tightly clamp Hitch to Bumper. Loosen Pressure Bolt to remove accessory. **Hitch is now ready to use!**

Visit [www.mount-n-lock.com/installs](http://www.mount-n-lock.com/installs) for full-size instructions.