

**1** Assemble Tray Pan

STEP 1 - TRAY PAN Assembly: Assemble TRAY PAN from 4 WEDGE SECTIONS using 8 Nuts & Bolts as Shown. Note How Opposing WEDGE SECTIONS (in Blue) Sit On Top of the Other Set of Opposing WEDGE SECTIONS (In Red).

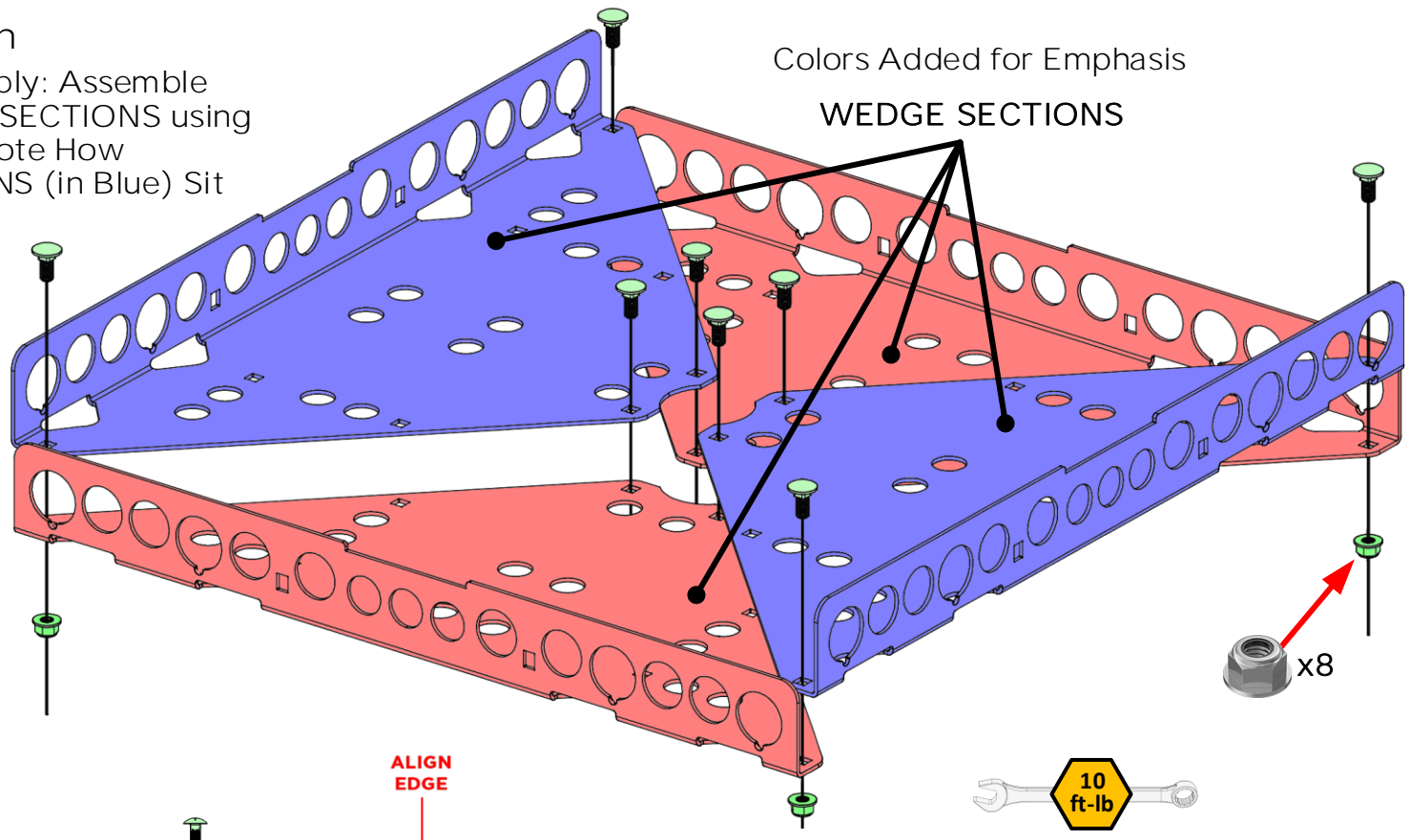

**2** Mounting Tray Pan to Support Arms - Alignment

STEP 2 - Alignment: Note how TRAY PAN edge aligns with SUPPORT ARMS.

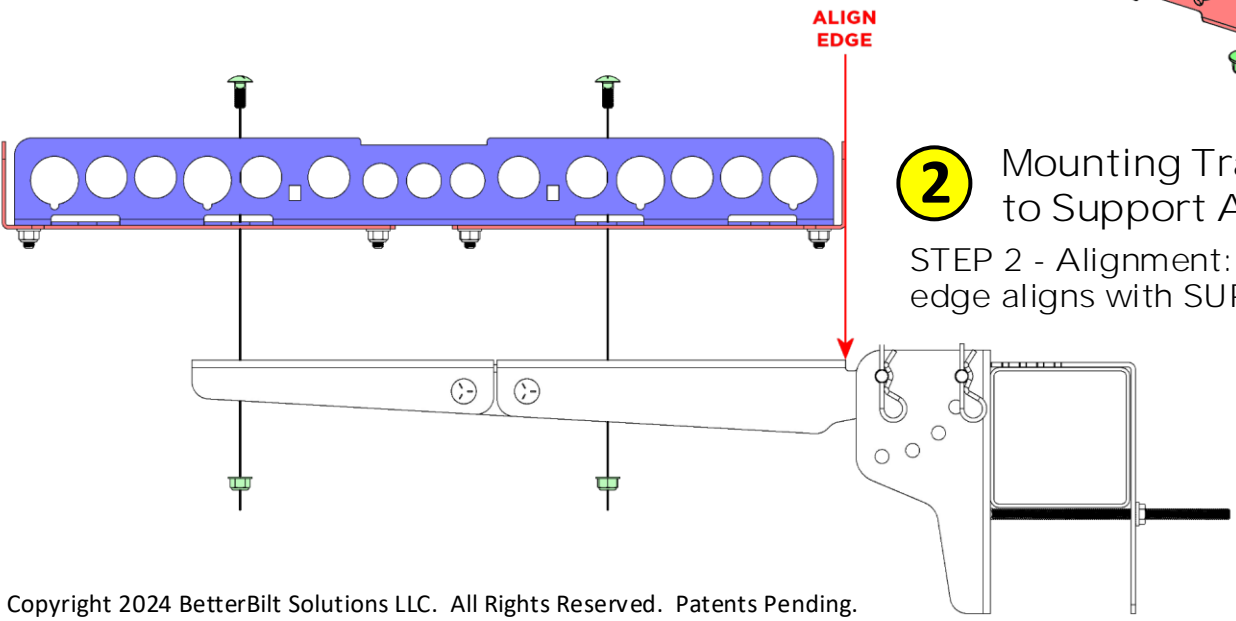

**GENNYGO**  
GENERATOR & CARGO CARRIERS

Proudly Made in the USA

**Haul It All!**

**MP**  
Mount-n-Lock  
INNOVATIVE  
RV CARGO

Use For Items:  
 GGPA  
 GGPS  
 F2KH2424  
 F4KH2424  
 F2KS2424  
 F4KS2424

**TRAY PAN/TRAY KIT  
 ASSEMBLY GUIDE**

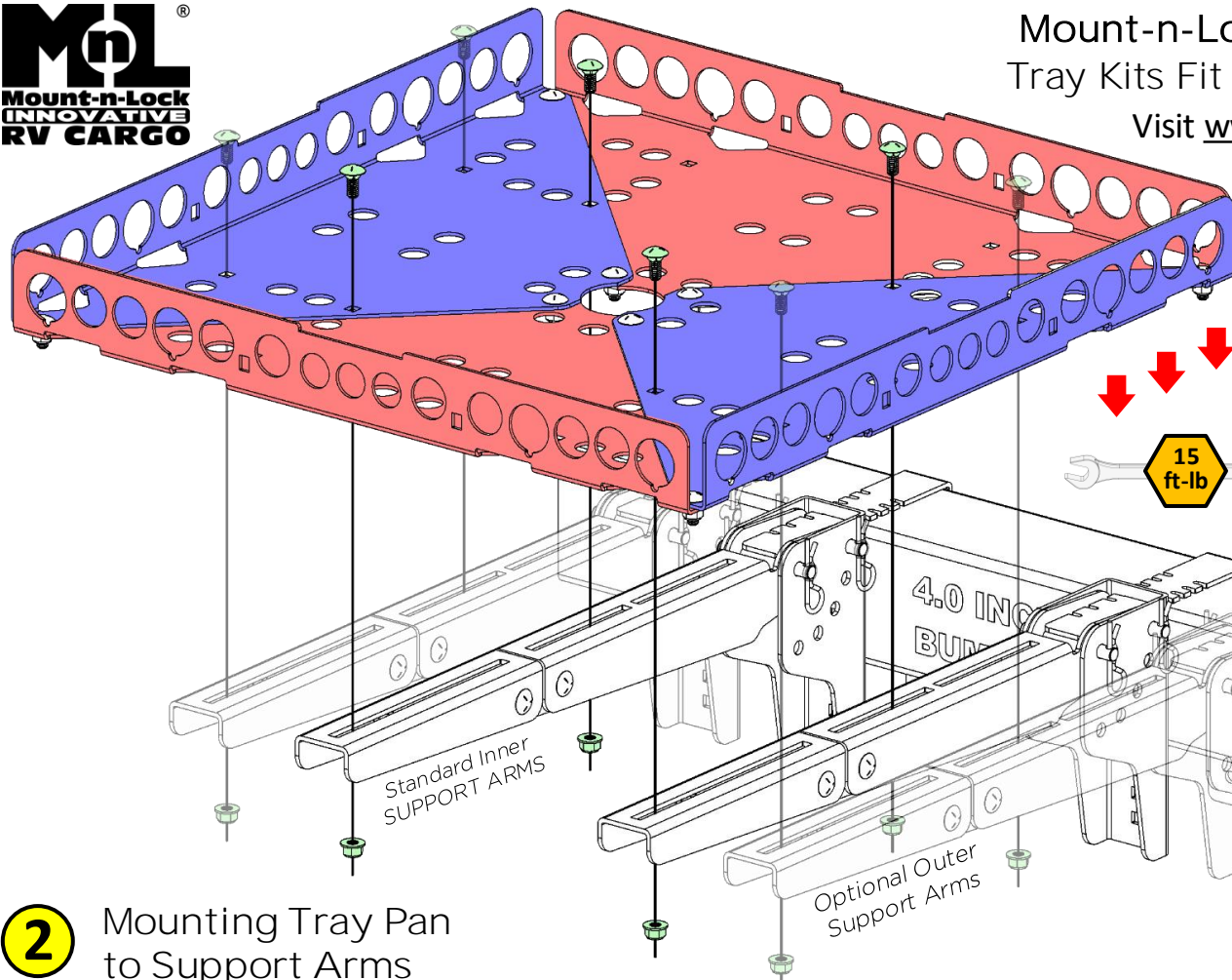

Colors Added for Emphasis

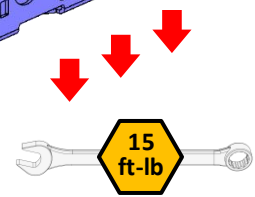

TRAY KIT

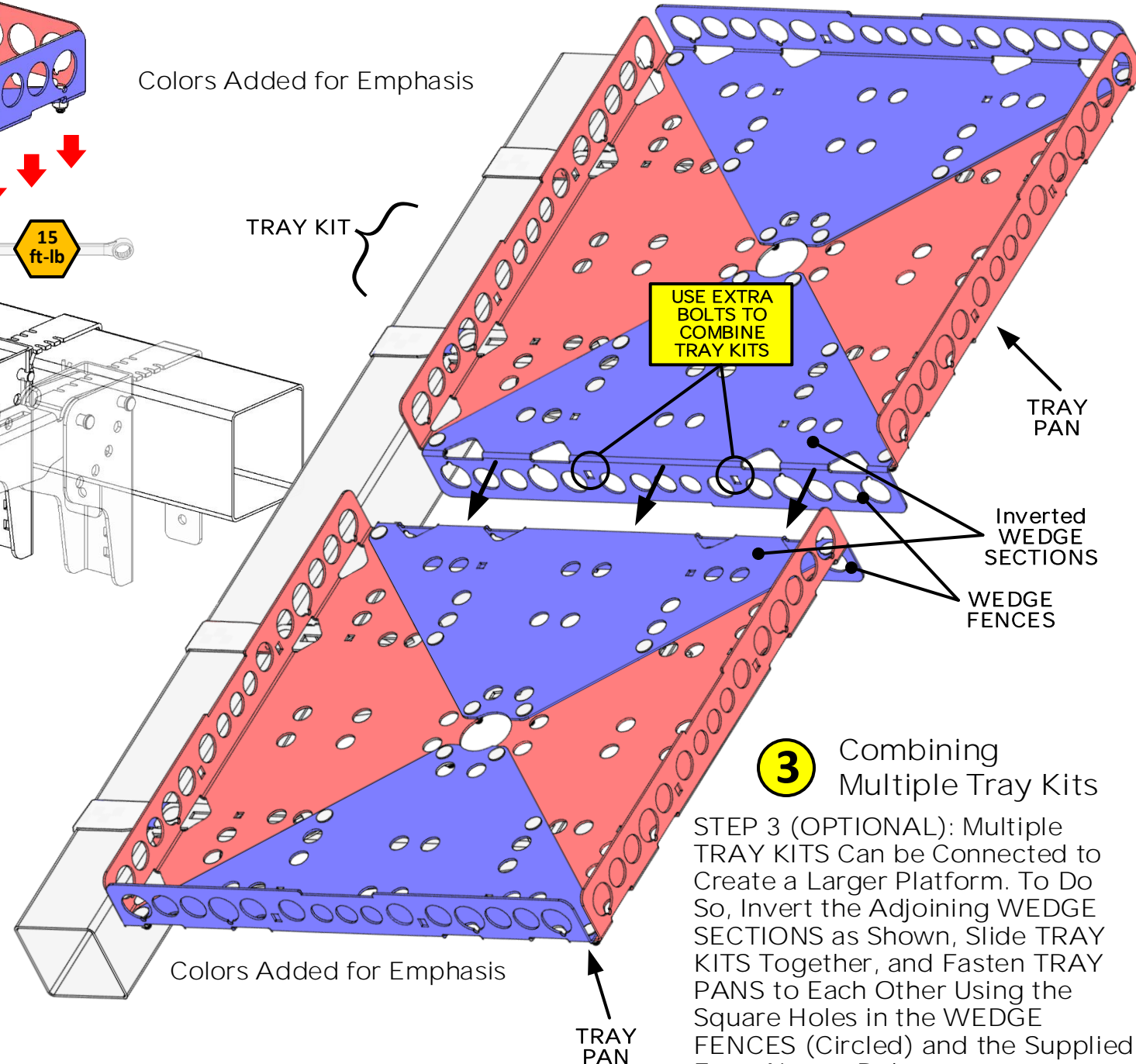

**2**

**Mounting Tray Pan to Support Arms**

STEP 2: After Assembling and Mounting the SUPPORT ARMS to Your BUMPER as Shown in Separate "Support Arms Assembly Guide" Document, You Will Mate the TRAY PAN From Step 1 to the SUPPORT ARMS using either 2 Nuts & Bolts per SUPPORT ARM.

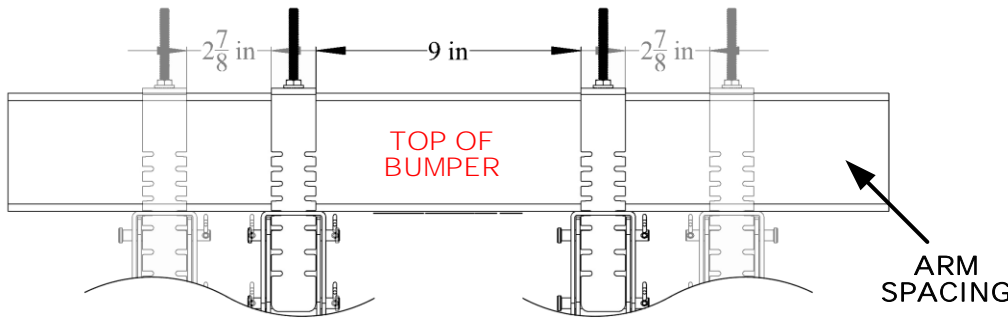

**3**

**Combining Multiple Tray Kits**

STEP 3 (OPTIONAL): Multiple TRAY KITS Can be Connected to Create a Larger Platform. To Do So, Invert the Adjoining WEDGE SECTIONS as Shown, Slide TRAY KITS Together, and Fasten TRAY PANS to Each Other Using the Square Holes in the WEDGE FENCES (Circled) and the Supplied Extra Nuts & Bolts.